

INDEX

FEATURES	1
APPLICATION	1
SPECIFICATIONS	2
DIMENSIONS	2
SAFETY AND WARNING	3
CONFIGURATION AND CONNECTION	3
INSTALLATION	4
ACCESSORIES	4
ORDERING CODE	4
TROUBLE SHOOTING	4

Isolated & Programmable Temperature Transmitter

- TT7S10-H: Loop Powered Head Mount
- TT7S10 : Loop Powered DIN Rail Mount
- TT7S11S : Aux Powered DIN Rail Mount

Isolated. Universal. Accurate

TT7S series Transmitters are designed for Isolated and accurate Temperature measurements and signal conditioning Applications. Model TT7S10-H is 2 Wire Loop powered Head Mount Transmitter, Model TT7S10 is 2-wire Loop powered Din Rail Mount Transmitter and Model TT7S11S is 4-wire Auxiliary powered Transmitter. All models are programmable for Thermocouples, Pt-100 RTD, mV and Resistance/Potentiometer. Output signal is standard 4-20mA in 2-wire & mA or Volts in 4-wire. Programming of the Transmitters is easy by means of user friendly mTRAN windows based configuration software.

FEATURES

- Universal input (RTD, Thermocouple, Ohm, mV)
- 1.5 KVAC Isolation between I/P & O/P
- Linearized Output
- Highly Accurate
- Fully Programmable for Input type & Range
- Fast Response time: <500 ms
- Digital Filter
- Windows mTRAN software for Configuration, Calibration & Monitoring
- Reverse polarity protection
- Direct/Reverse output
- Sensor break detection
- Loop/Aux Powered models
- Extended Power Supply Range of 20 to 265VDC/AC for Aux Power Transmitter TT7S11S

APPLICATION

- Power Plants
- Metal Industry
- Oil & Gas
- Chemical
- Glass Industry
- Cement
- Fertilizer

TT7S10-H



TT7S10



TT7S11S



SPECIFICATION

Input	
RTD	Pt100 3-Wire (3/4 Wire in TT7S11S)
Resistance/Potentiometer	0-2500Ω
Sensor current	~0.2mA
Thermocouple	E, J, K, T, B, R, S, N (ANSI standard) (See: Table 1)
mV	0-75mV/ 0-500mV DC
Input Impedance	> 1M ohms
Sensor burn out current	<1 uA
Input Sensor Range	Refer Table 1
Zero & Span Adjust	Through mTRAN Software
Accuracy	
E, J, K, T, N, PT-100/ mV, Ω	0.1% of FS± 1 Deg/count
B, R, S	0.25% of FS± 1 Deg
CJC Error	
E, J, K, T, N	±2 °C
B, R, S	±3 °C
Stability	±0.1% per year
Response time	< 500msec
Digital Filter	0-20 sec settable through software, (2 sec default)
CMRR	> 120 dB
NMRR	≈ 40 dB
Temperature co-efficient	<150ppm
Output	
TT7S10 & TT7S10-H	
Output	4-20mA or 20-4mA (User Selectable)
Resolution	1 uA
Sensor break Output	Lo < 3.4 mA or Hi >20.8 (User Selectable)
Output load	R load= (Voltage supply - 8.5)/0.021 Ohm (TT7S10 and TT7S10-H)
TT7S11S	
Output	0/4-20mA, 0/1-5V, 0/2-10V (User Selectable)
Output Direction	Direct / Reverse (User Selectable)
Resolution Current	1 uA
Voltage	0.25 mV (0/1-5V), 0.5mV(0/2-10V)
Sensor break Output	Lo < 3.4mA or Hi >20.8mA (user set)
Output Load	mA: Load Voltage ≤ 15V (e.g. for 4-20mA: 15V/20mA ≤ 750Ω) V: Load Current ≤ 1.25 mA (e.g. for 0-5V: 5V/1.25mA ≥ 4 KΩ)
Supply	
TT7S10 & TT7S10-H	8.5-36 VDC 2-Wire
TT7S11S	20-265V DC/AC (45-65Hz) <3VA
Isolation	
TT7S10 & TT7S10-H	1.5KVAC Galvanic for 1 minute between I/P & O/P
TT7S11S	
Input /Output/Supply	1.5KVAC Galvanic for 1 minute between all ports
Physical	
Mounting	
TT7S10 & TT7S11S	35 mm DIN Rail
TT7S10-H	Sensor Head (35 mm DIN Rail-Optional Accessory)
Dimensions	
TT7S10 & TT7S11S	12.5(W)x99(H)x114.5(D) mm
TT7S10-H	Diameter(46mm) x Height(28mm)
Enclosure Material	
TT7S10-H	Polycarbonate
TT7S10 & TT7S11S	Polyamide
Environmental	
Operating temperature	
TT7S10-H	-40 to 85 °C
TT7S10	-40 to 55 °C
TT7S11S	0 to 55 °C
Storage temperature	-20 to +85 °C
Humidity	30 to 95% (Non-condensing)
Terminal Detail	
Terminal Block	UL,CSA standard & CE certified
Terminal Cable Size	2.5mm ²

1. Dimensions

1.1 TT7S10-H

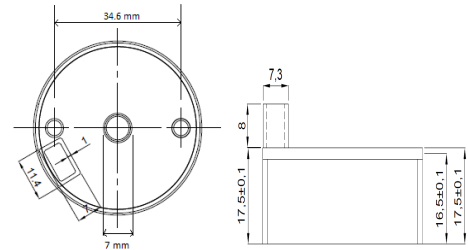

1.2 TT7S10& TT7S11S

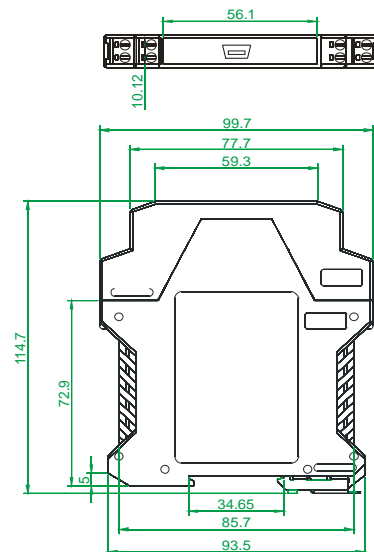

All dimensions are in mm.

Table1: Input Sensor Range

Input Type	Ranges
E	-200 to 1000°C
J	-200 to 1200°C
K	-200 to 1370°C
T	-200 to 400°C
B	450 to 1800°C
R	0 to 1750°C
S	0 to 1750°C
N	-200 to 1300°C
Pt-100	-200 to 850°C
LINEAR	0-75mV/ 0-500mV
Potentiometer	0-2500Ω

Input Type	Span Adjustment
0-2500 ohms	> 1K ohms (1uA Resolution)
	>200 ohms (5uA Resolution)
	>400 ohms (5uA Resolution)
0-75mV	>30mV (1uA Resolution)
	>10mV (5uA Resolution)
0-500 mV	>200mV (1uA Resolution)
	>50mV (5uA Resolution)

SAFETY AND WARNING

To avoid Electrostatic Discharge (ESD) to the transmitter, which may cause permanent damage, always ground yourself by touching some ground equipment before configuring the transmitter.

Before installation or beginning of any troubleshooting procedures the power to all equipment must be switched off and isolated. Units suspected of being faulty must be disconnected and removed first and brought to a properly equipped workshop for testing and repair.

Component replacement and interval adjustments must be made by a company person only. Wiring must be carried out by personnel, who have basic electrical knowledge and practical experience.

All wiring must confirm to appropriate standards of good practice and local codes and regulations. Wiring must be suitable for voltage, current, and temperature rating of the system. Beware not to over-tighten the terminal screws.

CONFIGURATION AND CONNECTION

TT7S series transmitters are configurable through configuration software "mTRAN".

Configuration and calibration should be done in nonhazardous area.

Once configuration is done, parameters are changed.

Connection details:

TT7S10-H

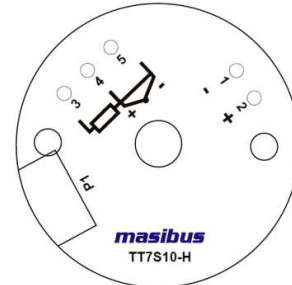

Terminal 3, 4 & 5: For RTD/Potentiometer Input

Terminal 4 & 5: For T/C & Linear Input

Terminal 1 & 2: For Loop Power and Output

TT7S10

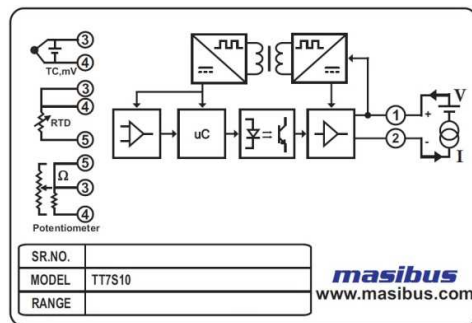

Terminal 3, 4 & 5: For RTD/Potentiometer Input

Terminal 3 & 4: For T/C & Linear Input

Terminal 1 & 2: For Loop Power and Output

TT7S11S

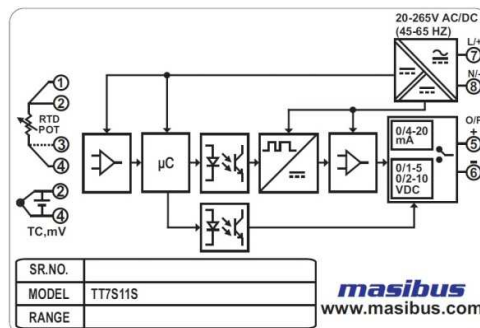

Terminal 1, 2, 3 & 4: For RTD/Potentiometer Input

Terminal 2 & 4: For T/C & Linear Input

Terminal 7 & 8: Power Supply Input

Terminal 5 & 6: For Output

INSTALLATION

Din Rail Mounting:

The unit can be snapped onto all DIN rails (35mm) According to EN60715. The device must be mounted horizontally (Supply terminal blocks facing upper wards)

The housing is mounted on the DIN rail by swiveling it into place. Adequate Air circulation must be considered between each Aux Powered devices to maintain their Operating temperature ranges, by keeping some space between each devices.

Removal:

Release the Snap-On catch using a screwdriver and then detach the module from the **bottom edge** of the DIN Rail.

Head Mounting:

The Unit can be mounted with 2 screws given with the sensor head as shown in figure with screw driver.

TT7S10, TT7S11S

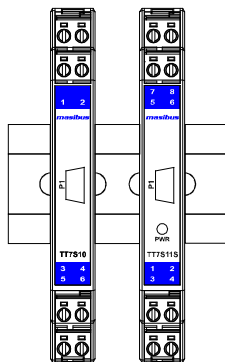

TT7S10-H

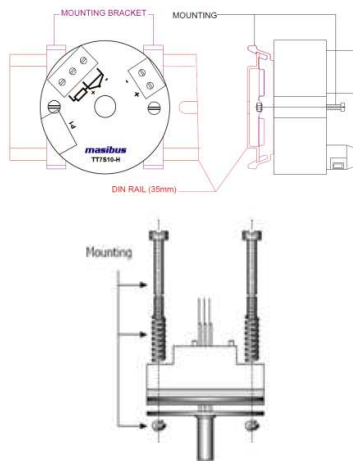

ACCESSORIES

Mounting Kit

Head Mounting: m-MK-FH-00-1 (Only For TT7S10-H)

Rail Mounting Kit: m-MK-RC-10-1 (Only for TT7S10-H)

Cable Accessories

Sr. No.	Description of Accessories	Part No.	Qty
1	Configuration cable For TT7S10, TT7S10-H & TT7S11S	m-cb-5-4-7-10-0-0-1-1	01

ORDERING CODE

Model	Transmitter Type	Input Type	Output
TT7S	10 Loop-Powered Din Rail Mount	1 E	1 4-20mA
	11S Aux-Powered Din Rail Mount	2 J	2* 0-20mA
	10-H Loop-Powered Head Mount	3 K	3* 1-5V
		4 T	4* 0-10V
		5 B	5* 0-5V
		6 R	6* 2-10V
		7 S	
		8 N	
		9 Pt-100	
		U	0-75mV
		H	0-500mV
		I	0-2500Ω

*Available in Aux Powered model TT7S11S Only

TROUBLE SHOOTING

⚠ Unit Not Turning ON?

TT7S10&TT7S10-H - If transmitter is not delivering loop current, check the circuit from Power supply, two wire transmitter & receiving device. If still transmitter is not delivering loop current, check the supply connections and polarity of 24Vdc terminals.

TT7S11S - If RED LED at the front side is not turned "ON", the device is not getting sufficient supply or the connections are not as per terminal details.

⚠ Output not matching with expected value?

Make sure the load on output of device is as per specification criteria.

⚠ Communication with PC is not proper (for all models)

The reason can be in pc driver is not installed, Comport is not proper selected, Or connection from PC to unit is loose.

masibus Automation & Instrumentation Pvt. Ltd.
B/30, GIDC Electronics Estate, Sector- 25,
Gandhinagar-382044, Gujarat, India
Ph: 91-079-23287275 / 76 / 77 / 78 / 79
Fax: 91-079-23287281/ 82
Email: support@masibus.com
Web: www.masibus.com